

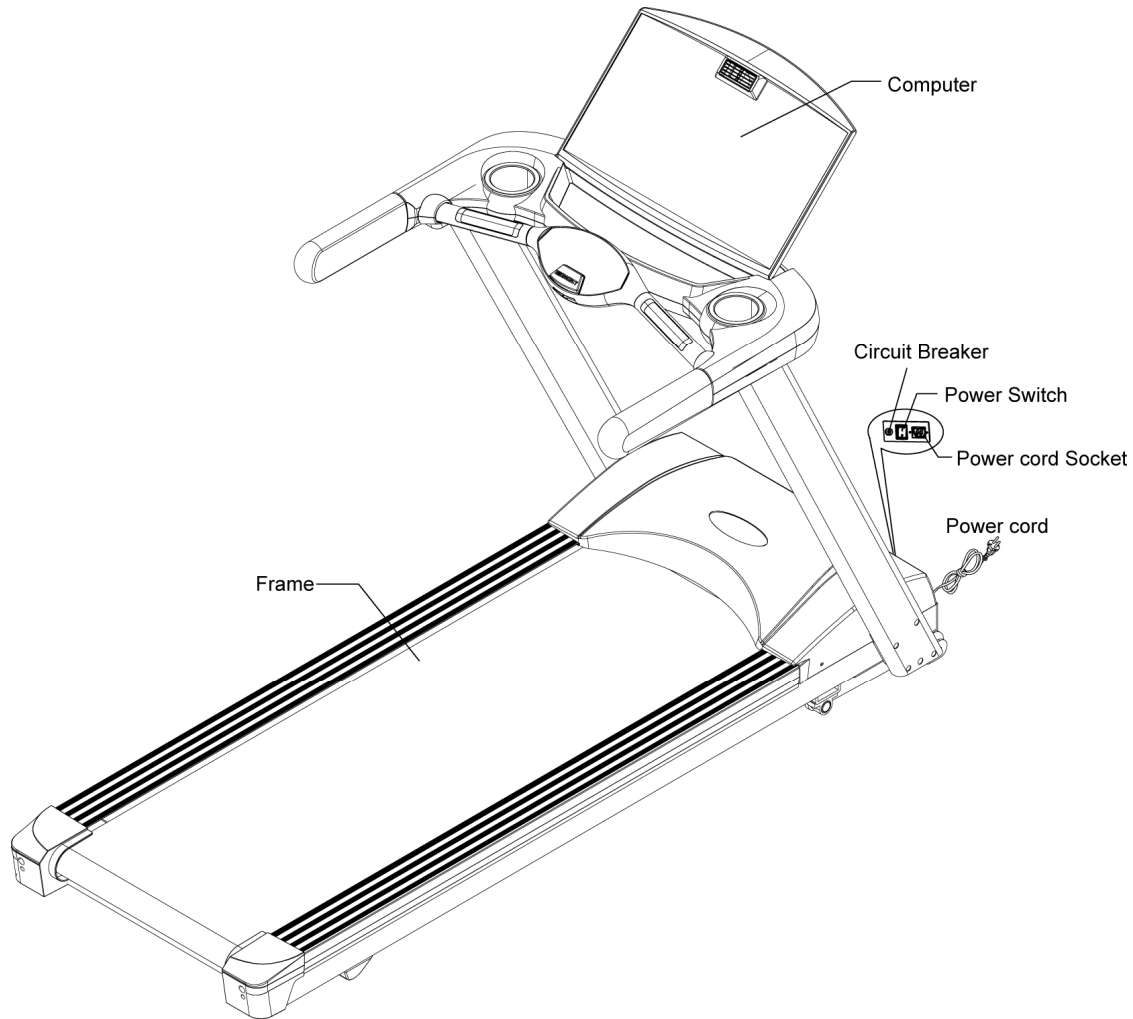

Treadmill Owner's Manual

BH Fitness T7



BH FITNESS

20155 Ellipse, Foothill Ranch, CA 92610

Phone: 949-206-0330, Fax: 949-206-0013

Email: fitness@bhnorthamerica.com

Web: www.bhnorthamerica.com and www.bhfitness.com

Issued: 18 July 2008 (v1)

Revised: 20 November 2008 (v2)



TABLE OF CONTENTS

SECTION	PAGE
Safety Instructions	2
Assembly	5
Maintenance.	10
Lubricating and adjusting the belt.	11
Removing and washing the bottle holder	14
Fitness and Exercise	15
Troubleshooting	17
Computer Console	18
Warranty	25



USER SAFETY INSTRUCTIONS

PRECAUTIONS

This treadmill has been designed and constructed to provide maximum safety. Nevertheless, certain precautions should be taken when using exercise equipment. The following safety instructions should also be taken into consideration: Always observe basic safety precautions when using the treadmill, including the following:

1. Users should pass a full medical examination before they embark upon any type of exercise program.
2. For safety, maintain a minimum clearance around the treadmill. Maintain 18 inches on the front and on each side of the treadmill plus 24 inches at the rear of the treadmill.
3. To guarantee your safety and that of the equipment read through the entire manual carefully before assembling and/or using the treadmill.
4. To ensure correct and safe use of the equipment, make sure that all those who use the machine have read this manual or are aware of its content. The contents of this manual should form part of your training program.
5. To reduce the risk of electric shock, always unplug the unit before proceeding to carry out cleaning and/or maintenance tasks.
6. To reduce the risk of burns, fire, electrical shocks or personal injuries, observe the following precautions:
7. Do not allow children or people who are unfamiliar with the operation of the appliance get too near and/or on the unit. Under no circumstances must this appliance be used as a toy.
8. Do not leave the treadmill operating unsupervised. Unplug the unit from the power supply when not in use and before cleaning it or removing any of its component parts. Never adjust the drive belt while the treadmill is being used.
9. Install and use the treadmill on a flat, stable surface. Do not place it alongside walls or furniture. Check the unit before each use and make sure that the belt is in good condition.
10. Keep the treadmill in good working order.
11. The treadmill must only be used as described in this manual. Do not use accessories that are not recommended by the manufacturer, as these may cause injuries.
12. The treadmill can only be used by one person at a time.

SAVE THESE INSTRUCTIONS



TREADMILL SAFETY AND GENERAL INSTRUCTIONS

18. Do not use the machine if the power cord becomes damaged or worn.
19. Do not tug on the power cord in order to unplug the unit.
20. Keep the plug and power cable away from hot surfaces.
21. Do not use the equipment in areas where aerosol sprays are used.
22. Do not use the machine outdoors.
23. Do not attempt any maintenance and/or repair work other than that stated in this manual.
For more complicated tasks, please get in touch with your technical assistance service.

SAFETY BREAKER

This model is equipped with an electronic circuit breaker to protect both the electronic and electrical circuits. Figure B.

The circuit breaker will be automatically triggered if the unit is subjected to abnormal force or heat.

Should this occur:

1. Set switch (L), located on the main body, to the "0" (OFF) position.
2. Press the circuit button (C) to reset the unit.
3. Next, set switch (L) to the "1" (ON) position and the unit will be ready for use again.

Should the circuit breaker trip repeatedly then the most probable causes are:

- Abnormal working conditions,
- Treadmill belt in need of lubricant (Figure (7)),
- Solvent based lubricants used (use BH type),
- Belt is too tight.

Plug the unit into a wall socket with a ground terminal. Set switch (L) to Position [1].

Figure B

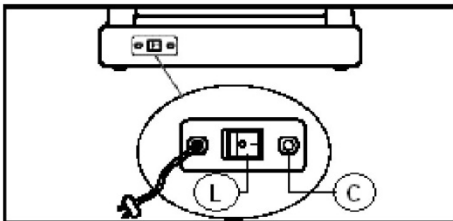

ASSEMBLY

ASSEMBLY INSTRUCTIONS

Take the unit out of the box and place it on the floor as shown in Figure 1. Verify that the parts are undamaged and quantities are correct.

ATTENTION: The assistance of a second person is advisable for the assembly work.

Follow the assembly instructions step by step:

ITEM	DESCRIPTION	Qty
A	Computer Console	1
B	Frame	1
C	Handle/Holder Set	1
D	Right Upright	1
E	Left Upright	1
F	Bottle Holder	2
G	Bottle	1

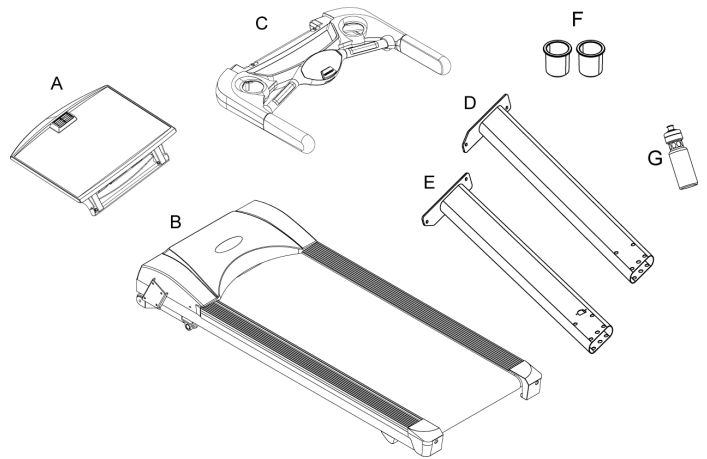

ITEM	Description	Qty
a	SK-415 Bolt	8
b	Nylon Nut M8	4
c	Truss Hex Bolt M8xP1.25x45	2
d	Plastic Handle	2
e	Hex Wrench 6mm x 80mm x 80mm	1
f	Hex Wrench 5mm x 80mm x 80mm	1
g	Power Switch Cover	1
h	T Shaped Wrench 8mm x 200mm	1
i	Sleeve Spanner (wrench) + Screw Driver	1
j	Bottle of SILICONE Lubricant	1
k	Power Cord	1

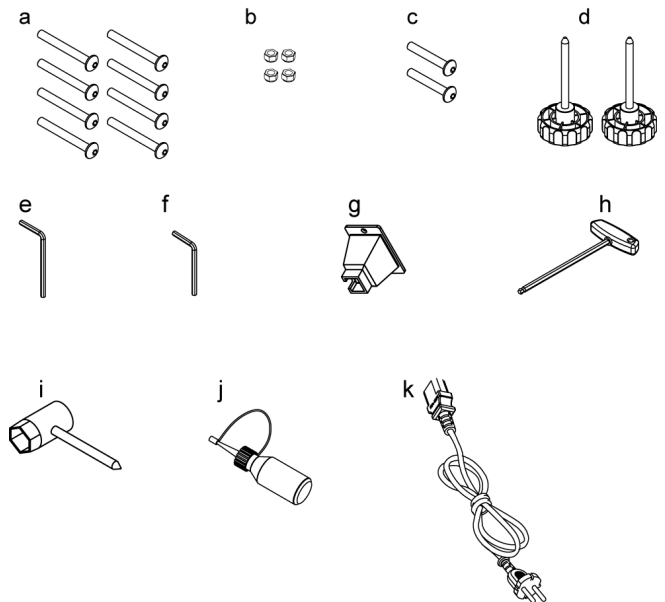

1. As required, use the fishing line inside of uprights (D, E) to bring wire up from Frame through upright to the top of upright.
2. One assembler hold the upright.
3. Second assembler tighten the left and right uprights (E, D) on the frame with Bolt (a). Be careful not to damage wires.

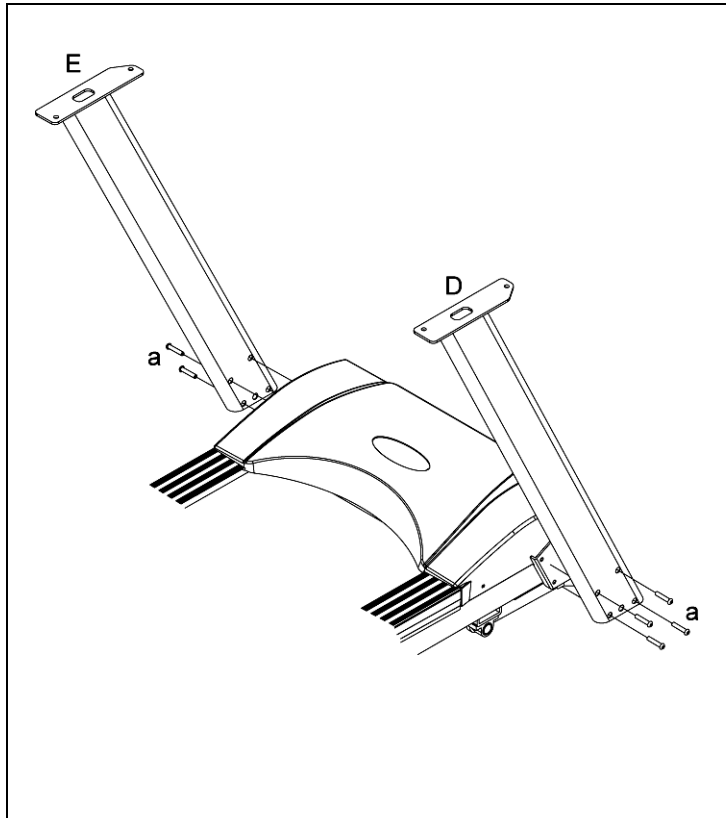

4. Pass wire from Upright into Handle/Holder Set (C) through cup holder space to the rear of (C). See small figure.
5. Fasten Handle/Holder Set (C) onto uprights (D, E) with Nylon Nut (b).
6. Verify wire appears at the rear of (C). See small figure.

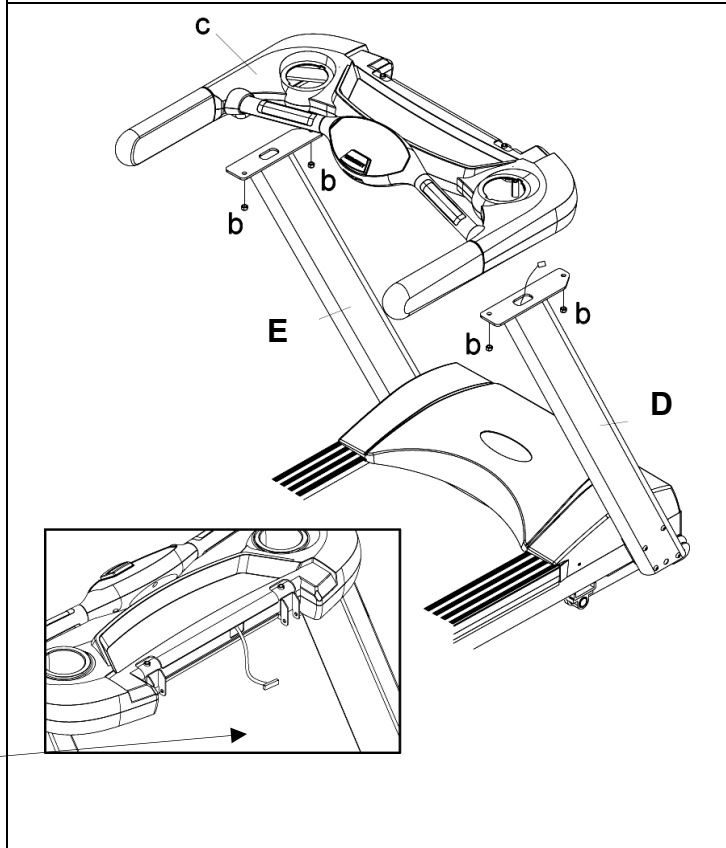

Bring wire to rear

- Remove the two fasteners and the cover under the computer console (A) according to the arrowhead in the right drawing. Save two fasteners for reuse.

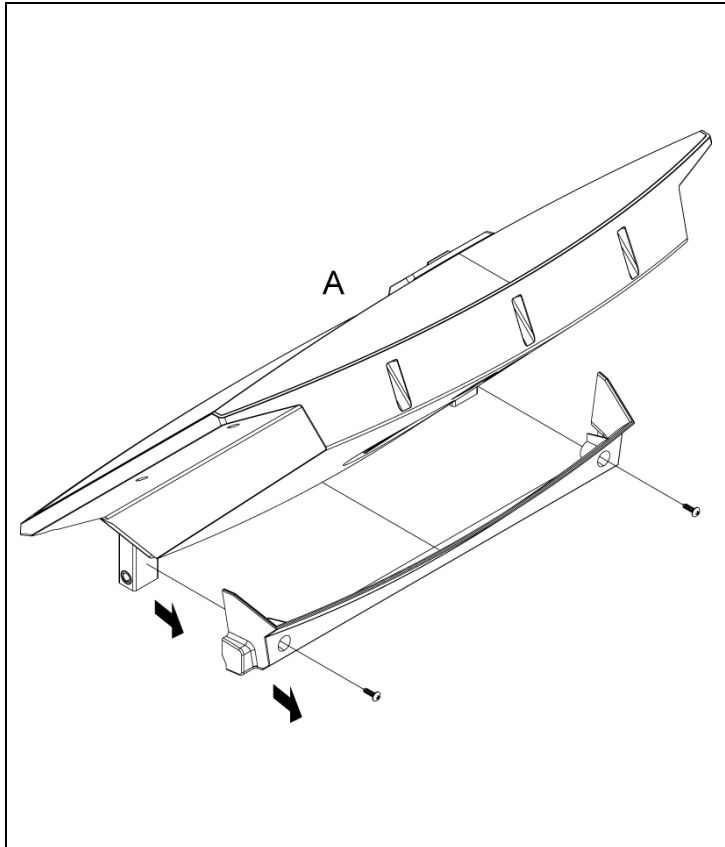

NOTE: Two Assemblers are required.

- Connect the lower control wire of Handle/Holder Set (C) and the upper control wire of Computer Console (A).
- Fasten the computer on Holder (C) with Bolt (c).
- Reinstall the cover under the computer console (A). Reuse the two fasteners removed in step 7.
- Tighten the computer console (A) with plastic handles (d).

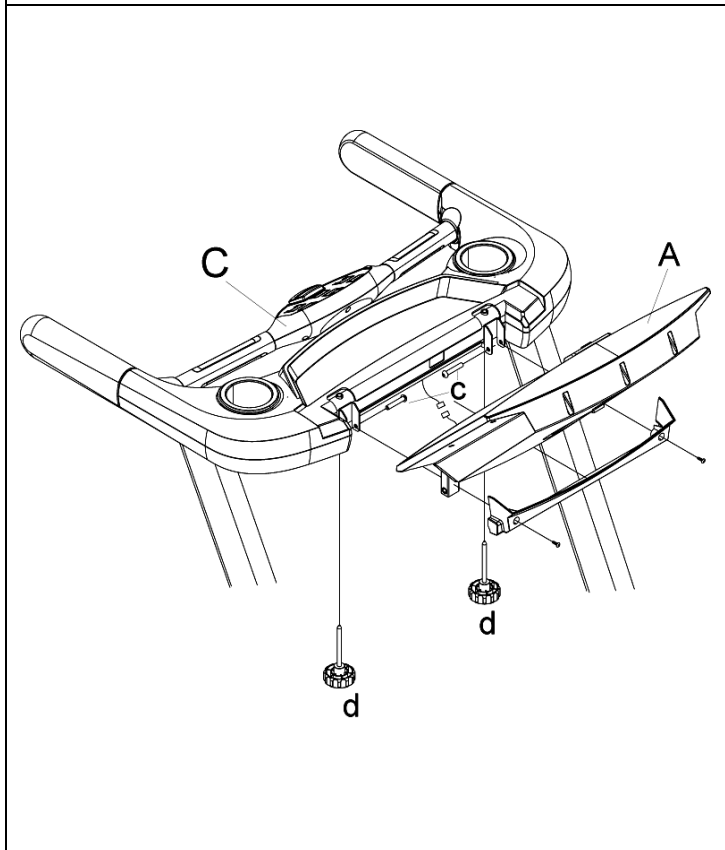

12. Put the bottle holders (F) into the Holder (C) and turn to hold firmly.

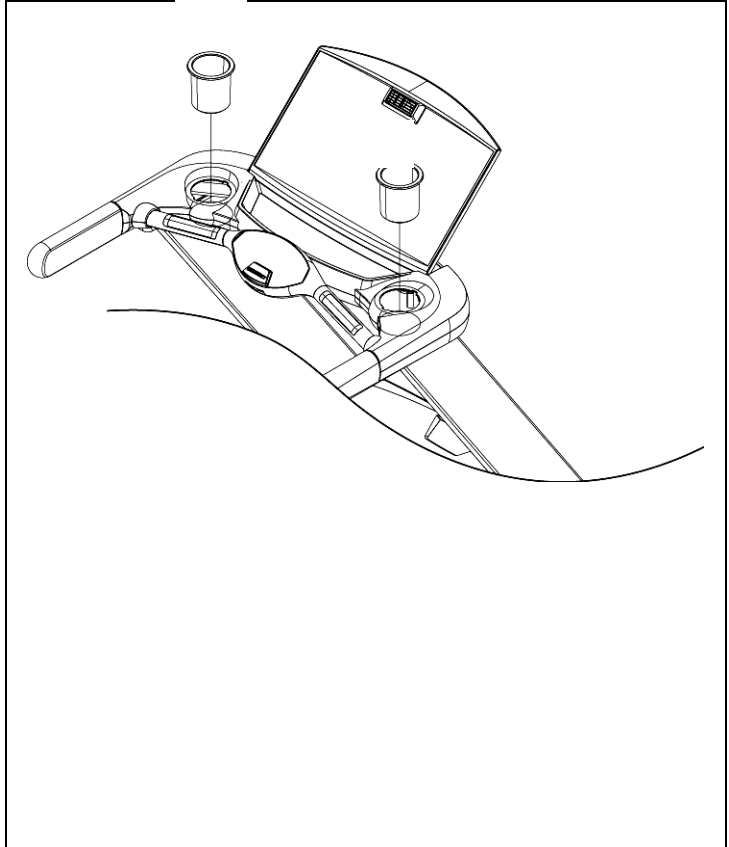

13. As required, install the Power Switch Cover (g) over the Power cord (k).

14. As required, insert the Power cord into the Frame.

15. As required, screw the Cover (g) to the Frame.

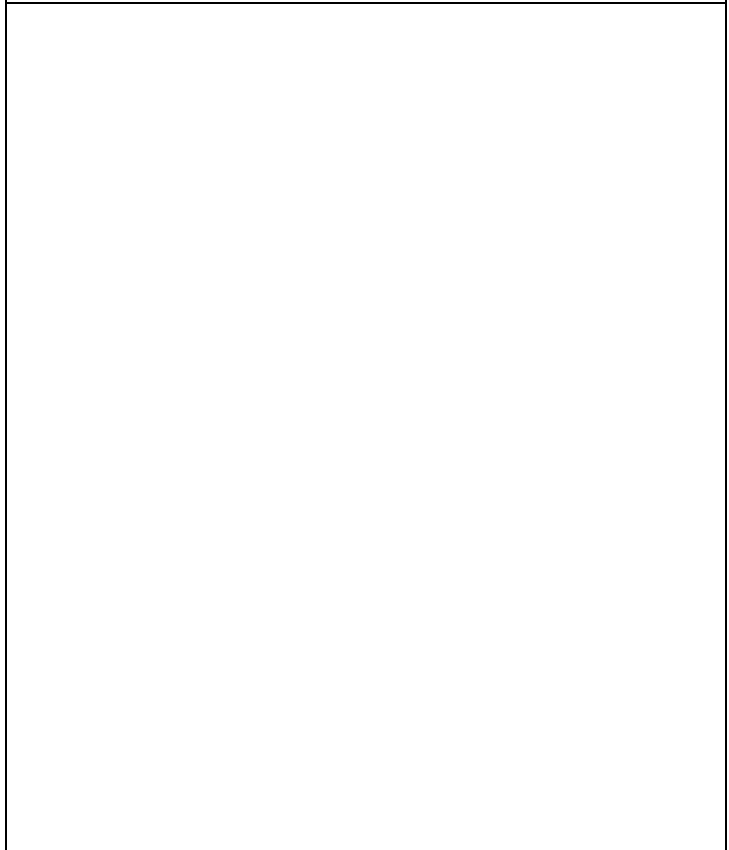



ASSEMBLY CONTINUED

POSITION THE TREADMILL

1. For safety, maintain a minimum clearance around the treadmill. Maintain 18 inches on the front and on each side of the treadmill plus 24 inches at the rear of the treadmill.

NOTE: Safe movement of the treadmills is explained in the MAINTENANCE section of this manual.



MAINTENANCE

LEVELING

Once the unit has been placed into its final position for doing exercise, make sure that the treadmill sits flat on the floor and that it is level. This can be achieved by doing the following:

A) - Switch the treadmill on to see if the console shows that the treadmill is at zero inclination level.

B) – Once you have checked the inclination, place a spirit level on the running belt

MOVEMENT & STORAGE

NOTE: Lift and roll the treadmill using two people.

NOTE: To prevent accidents DO NOT move the treadmill across uneven floors.

The treadmill is easier to roll if the incline is higher than zero. Unplug the power cord prior to moving the treadmill. To move the treadmill, tilt the treadmill, so that the front wheels rest on the floor.

MAINTENANCE

LUBRICATION

Figure 7. Use the bottle of lubricant (h) to lubricate the inside of the belt in order to keep your unit in top condition and to ensure that friction between the belt and the board is kept to a minimum (due to different running styles, always apply more lubrication to the area where you place your feet during the exercise). It is advisable to lubricate the base of the belt every 3-12 months, depending on how often it is used.

If the belt starts to slip after lubrication, then check the tension of the belt. To tension the belt, Figure 8, take the Allen key (m) and with the machine set to 2.5 miles/hr (4 km/h) turn screws (R & L) one full turn in a clockwise direction.

Table I

Operating Speed	Recommended lubrication period for home use. Lubricate monthly for business use
1 to 3.7 miles (1 to 6 km) per hour	1 year
3.7 to 7.4 miles (6 to 12 km) per hour	6 months
7.4 to 9.9 miles (12 to 16 km) per hour	3 months

Do not use solvent based lubricants.

Figure 7

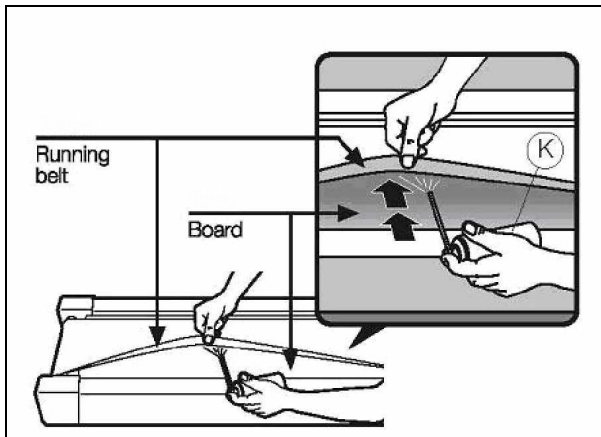
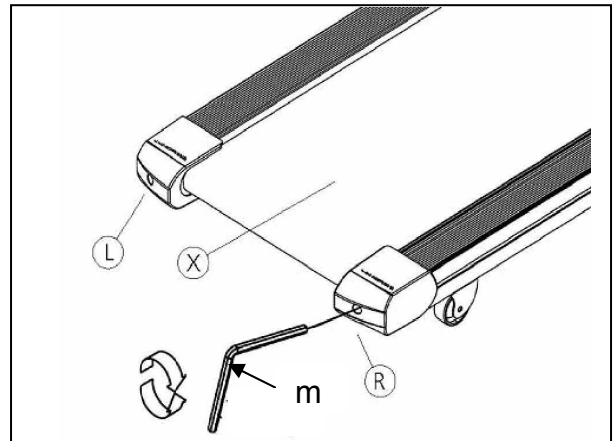

Figure 8





MAINTENANCE

ADJUSTING THE BELT

If your unit is not seated evenly on the four contact points, this may cause the belt shown on Figure 8, area (X) to shift sideways. Rigorous quality control adjusts and checks the running belt. However, due to weight differences and individual styles of running, the belt may be prone to shift sideways.

If the belt does shift to the left or right, stop the machine and adjust the belt.

NOTE: Over tightening of the belt can lead to a loss of speed on the machine and even stretch the belt itself. Bear In mind that one turn of the right screw (R) in a clockwise direction has the same effect on the position of the belt as one turn of the left screw (L) in a counterclockwise direction. Consequently, in the event of excessive belt movement you can use either of the two screws in order to avoid over tightening the belt.

BELT SHIFTED TO THE RIGHT (Figure 8)

1. Turn off and unplug the treadmill each time before using the hex wrench.
2. Use the hex wrench to turn the right hexagonal head socket a 1/4 turn clockwise.
3. Turn on treadmill for a few minutes at a speed of 2.5 mph (4 km/h) and check belt location.
4. If the belt is not centered, then turn the left hexagonal head socket a 1/4 turn counterclockwise.
5. If the belt is not centered, then repeat steps.

BELT SHIFTED TO THE LEFT (Figure 8)

1. Turn off and unplug the treadmill each time before using the hex wrench.
2. Use the hex wrench to turn the left hexagonal head socket a 1/4 turn clockwise.
3. Turn on treadmill for a few minutes at a speed of 2.5 mph (4 km/h) and check belt location.
4. If the belt is not centered, then turn the right hexagonal head socket a 1/4 turn counterclockwise.
5. If the belt is not centered, then repeat steps.

TREADMILL CLEANING

Switch the unit off and unplug the power cable. Use a damp cloth or towel to clean the dust off the treadmill, especially the side bars and the electronic console. Do not use solvents.

NOTE: Unplug the treadmill before using a vacuum near the treadmill.

Use a vacuum cleaner to carefully vacuum around the visible components (belt, structure, etc.). You can increase the INCLINE in order to vacuum the underside of the unit. You can vacuum the inside of the motor housing by removing the cover that protects the motor (be careful with the wires).

NOTE: Press STOP to lower the INCLINE.



MAINTENANCE

TIGHTENING THE FASTENERS

Check the connections and tighten all the parts on your unit every three months.

Use of this machine with worn parts, e.g. the drive belt, running belt or rollers, may cause the user injury. If you are unsure about the condition of any part, we recommend that you replace it with original spare parts. The use of other spare parts may cause injuries or affect the performance of the machine.



MAINTENANCE CONTINUED

REMOVING & WASHING THE BOTTLE HOLDER

To check if the Bottle Holder is held loosely, gently push the Bottle Holder up from beneath. If this does not release the Bottle Holder, then remove as follows:

RIGHT BOTTLE HOLDER REMOVAL OR INSTALLATION:

Gently grasp the Bottle Holder from beneath or on the rim. Turn it clockwise to unfasten. Once the Holder is loosened, lift the Holder up and out of the hole.

To install a Bottle Holder into the right hole:

Move away the wires.

Insert the Holder into the hole and gently turn counterclockwise to fasten.

LEFT BOTTLE HOLDER REMOVAL OR INSTALLATION:

Gently grasp the Bottle Holder from beneath or on the rim. Turn it counter-clockwise to unfasten.

Once the Holder is loosened, lift the Holder up and out of the hole.

To install a Bottle Holder into the left hole:

Move away the wires.

Insert the Holder into the hole and gently turn clockwise to fasten.

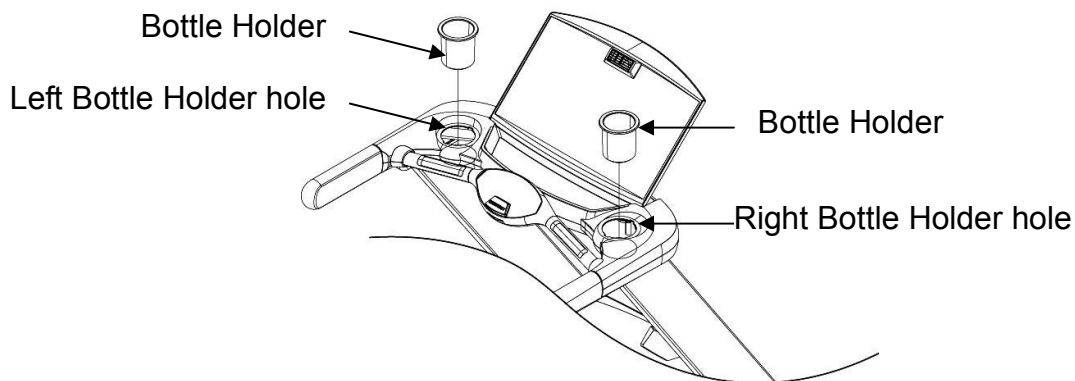

BOTTLE HOLDER WASHING

Please wash the Bottle Holders by hand only. The Bottle Holders cannot be placed into the dishwasher or microwave.



FITNESS AND EXERCISE

FITNESS

All doctors agree that regular exercise is a good way to control our weight, make us more fit and help us to relax. Before starting any exercise program, it is advisable to consult your doctor. You will achieve better results based on his/her advice or suggestions. Exercise programs vary depending on age and physical condition.

ADVANTAGES OF EXERCISE

Regular exercise below a certain level for 15/20 minutes becomes aerobic. Aerobic exercise is basically exercise that uses oxygen. Normally, this is a continuous exercise without pauses. In addition to sugars and fats, the body also needs oxygen. Regular exercise improves the body's ability to supply oxygen to all of the muscles and at the same time improve lung function, the heart's pumping capacity and better blood circulation. In short, the energy produced during exercise burns kilocalories (known as calories).

EXERCISE & WEIGHT CONTROL

The food we eat is transformed into, among other things, energy (calories) for our body. If we take in more calories than we burn then the result is an increase in weight and vice versa, if we burn more calories than we eat, we lose weight. When resting the body burns around 70 calories per hour to keep our vital functions active. The table shows approximate energy use for an average person doing various activities.

Table II

ACTIVITY	CALORIES USED PER HOUR
Walking, moderate pace	140
Housework	150
Swimming (400 m/h)	300
Dancing	350
Walking, brisk (6 km/h)	370
Tennis	420
Cycling (30 km/h)	500
Squash	690

EXERCISE PROGRAM

Regardless of whether your goal is to become more fit, control your weight or for physiotherapy, always remember that your exercise should be gradual, planned, varied and not too demanding. We recommend that you should exercise 3 to 5 times per week.

Before beginning a session it is important to do a warm-up for 2-3 minutes at low speed. This will help protect your muscles and prepare your cardio respiratory system.

The next stage will last 15-20 minutes at a pulse rate of between 65 to 75%, or between 75 to 85% for those already accustomed to exercise. At a later stage, once we have become fit, we can divide this time between both levels but always remembering that the pulse rate must not exceed 85% (aerobic area) and never reach the maximum heart rate limit that corresponds to our age.



FITNESS AND EXERCISE

When you have finished, it is important to relax the muscles. This can be done by walking at a low speed for 2-3 minutes until the heart rate drops below the 65% line. This will prevent muscle pain, especially after an intense session. It is also advisable to finish the program with some relaxation exercises on the floor.

FINAL NOTE

We hope that you enjoy your unit. You will soon notice the benefits of your controlled exercise program. You will feel better, have more energy and suffer less stress. You will see for yourself that it is worth staying in shape with BH Fitness.



TROUBLESHOOTING

Table III

PROBLEM	CHECKS	SOLUTIONS
1. The console does not switch on.	1a) Make sure that the machine is plugged in and the ON/OFF switch is in position I. 1b) Verify that the console electric supply cable is connected.	1a) Plug the machine into the power supply. Set the switch to position I. 1b) Connect the console electric supply cable.
2. The treadmill does not work	Check if the electrical outlets fuse or circuit breaker has shut off.	Repair fuse or circuit breaker. Contact a qualified electrician if required. Plug the treadmill into a dedicated 110-120V, 15 or 20 Amp outlet to ensure the treadmill receives the appropriate amount of current to function correctly. The outlet must not supply electricity to any other device.
3. Walking motion is jerky on the treadmill.	3a) Check if the belt is lubricated. 3b) Check the tension on the running belt. 3c) Check the tension on the AC motor drive belt drive belt.	3a) Lubricate the sliding belt. 3b) Adjust the belt tension. 3c) Adjust the drive belt tension.
4. The treadmill belt skews off center.	4a) Check if the machine is level on the floor. 4b) Check if the machine wobbles. 4c) Check alignment of the front and rear rollers.	4a, 4b) Use the adjustable feet to level the machine. 4c) Align the front and rear rollers.



CONSOLE OPERATION

BH Fitness **T7**

PROGRAM PROFILES

MANUAL 1 HOLE HILL CLIMB INCLINE RUN
 HRP HEART RATE INTERNAL ROLLING WEIGHT LOSS
 1 CUSTOM 2 CUSTOM 3 CUSTOM 4 CUSTOM

INCLINE SPEED

WEIGHT AGE TIME

Heart Rate Training Zone Index
 • Maximum Heart Rate = 220-Age

10	20	30	40	50	60	70	80	90	100
CARDIO TRAINING ZONE							90%		
FAT BURNING ZONE								72%	
55%									

○ CALORIES Kcal ○ INCLINE TIME Min : s ○ SPEED ○ DISTANCE
 ○ PULSE ○ WEIGHT ○ AGE ○ LEVEL

OPERATING INSTRUCTIONS

1. Turn on power switch and ensure safety key is attached.
2. Attach safety clip to clothing before startup.
3. To start For QUICK START Press **QUICK START** key
INCLINE keys control incline **SPEED** keys control speed
4. To end decrease speed and press **STOP** key

WARNING
 Removes safety key when not in use and store out of reach of children

CAUTION
 For your safety please consult owners manual before use
 Risk of injury to persons - To avoid injury stand on side rails before starting treadmill

2 | 4 | 6 | 8 | 10 | 12 INCLINE FAN 1 | 2 | 4 | 6 | 8 | 10 SPEED

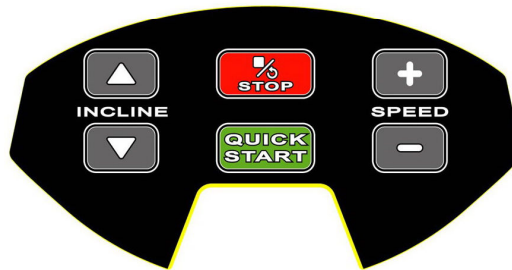



CONSOLE OPERATION CONTINUED

SAFETY KEY & CLIP

Your BH Fitness treadmill is equipped with a safety key that will disable the treadmill if it is not in place. You should attach the clip end to your clothing. The magnet end goes into the recess of the console. If at any time you need to stop the treadmill quickly simply pull the safety key off the console. This will cut all power to the treadmill and it will come to a complete stop. To resume your workout, place the safety key back in place. You will then need to program your workout again.

BEFORE STARTING

Straddle the running belt and stand on the side rails. Insert the safety key and attach the rope to your clothing. Do not stand on the walking belt while starting or stopping the treadmill.

KEY FUNCTIONS

UPPER CONTROLS:

ENTER – This key is used to input changes to programs.



These keys are used to change values during program setup. They cannot be used to adjust the speed and inclination while a program is operating.

TIME – This will read the number of minutes left in the program that you have selected except in “9 HOLE” and “QUICKSTART”. In “9 HOLE” and “QUICKSTART” it will read the number of minutes that you have been exercising.

CALORIES – This reading is the amount of body heat in calories burned during your workout. As with all pieces of exercise equipment, this is an estimated value.

INCLINE – Incline will read as a percent of incline.

PULSE – Pulse will read in Beats Per Minute (BPM).

SPEED – This is how fast you are moving in terms of Miles Per Hour (MPH).

DISTANCE – Total distance traveled during your workout displayed in miles.



CONSOLE OPERATION CONTINUED

INSTANT SPEED/INCLINATION BUTTONS – You can change the speed or inclination of the treadmill by pressing one of the Instant buttons. Each button represents the assigned value in either Miles Per Hour (MPH) or percent grade.

NOTE:

Additional information about Incline:

1. When the safety key is removed and put back, whatever the current position of incline, it will not return automatically to zero. The user must press the START or STOP button to return the incline to zero.
2. When the user turns off power and then turns it back on, whatever the current position of incline, it will not return automatically to zero. The user must press the Start key to return the incline to zero.
3. During a program, if you press the Stop to PAUSE, then the incline will return to zero.

FAN – Press this key to blow air from the vent located at the top center.

LOWER CONTROLS:

QUICKSTART – This key is used to begin any treadmill program or QUICKSTART.

STOP – This key is used to stop the treadmill at any time. Press STOP/RESET once to stop the running belt. Press STOP a second time and hold for 3 to 5 seconds until it beeps to end the program and set the incline to zero from an elevated position.

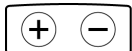

This key is used to adjust the speed of the treadmill.



This key is used to adjust the inclination of the treadmill.

TO STOP

1. Slow speed, step off running belt onto the side rails.
2. Press STOP. The running belt will stop. This key is used to stop the treadmill at any time. Press STOP/RESET once to stop the running belt. Press STOP a second time and hold for 3 to 5 seconds until it beeps to end the program and set the incline to zero from an elevated position.

NOTE: To stop immediately, pull out the safety key from the safety key recess and the treadmill will stop abruptly.



CONSOLE OPERATION CONTINUED

USING HEART RATE

GRIP PULSE – To periodically check your heart rate, grasp the sensors at the base of the console. The PULSE LED will flash and after about 9 seconds your pulse will be shown in the pulse window.

CHEST STRAP – Using your chest strap (such as a T41 POLAR transmitter), you can monitor your heart rate at any time during your workout. The heart rate strap will send your heart rate to the display and your pulse will be displayed. The transmitter is more effective if worn while you are sweating.

HEART RATE CALCULATION

Before beginning any test, calculate your maximum heart rate. The maximum number of heartbeats that a person must not exceed is referred to as the maximum heart rate and this value drops with age. A simple formula to calculate this is to subtract your age, in years, from the number 220. To ensure that you are exercising correctly, try to keep between 65% and 85% of your maximum heart rate value.

For example, the maximum heart rate that a 30 year old user must not exceed is:
 $220 - 30 = 190$ heart beats per minute (BPM).

$190 \times 0.65 = 123$ heart beats per minute.

$190 \times 0.85 = 161$ heart beats per minute. Do not exceed 85%.

So the heart rate exercise range for a 30 year old is between 123 and 161 BPM.

Stop exercising if your pulse is 85% of your maximum heart rate.

CONSOLE INSTRUCTIONS

Your BH FITNESS treadmill will provide both manual controlled and factory installed preset workout programs.

In **MANUAL** and **QUICK START**, you control the speed and/or inclination at your discretion.

In **PRESET** programs, the speed and/or inclination will change in accordance with the program's programming. There are 30 stages in each preset program, first 3 stages are **WARM UP**, and the last 3 stages are **COOL DOWN**. (No warm up or cool down in 9-Hole).

In any program, pressing the **STOP** key will **PAUSE** the current program. To resume the current program press the **QUICKSTART** key. To exit the current program press and hold the **STOP** key for 3 to 5 seconds until it beeps. Refer to heart rate calculation on page 21.





CONSOLE OPERATION CONTINUED



STARTING

1. Stand on the side rails.
2. Turn on the POWER. The window will display floating string PRESS WEIGHT BUTTON TO SET WEIGHT. Press WEIGHT. A blue and back colored LCD displays "LBS". Press the + or – keys on the upper controls to enter your weight. Press ENTER. A blue and back colored LCD displays an image of a heartbeat. The floating string in the window displays SELECT PROGRAM OR QUICKSTART.

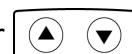
MANUAL PROGRAM SET UP

1. Stand on the side rails.
2. Press Manual program button in the upper left corner of the controls.
3. An LED will light up to indicate the program selected.
4. Time will be flashing.
5. Adjust time with the  or  keys at the upper controls.
6. Press ENTER at upper console to start.
7. Adjust Speed with instant speed keys or  at the lower controls.
8. Adjust Incline with instant incline keys or  at the lower controls.

9 HOLE PROGRAM SETUP

1. Stand on the side rails.
2. Press 9 HOLE program buttons located at the upper left corner of the controls. An LED (Light emitting Diode) will light up indicating the program selected.
3. Resistance level **X.XL-XX** will flash on the display.
4. Adjust level using the  or  keys on the upper controls.
5. Press ENTER. Time counts up from zero.









CONSOLE OPERATION CONTINUED





HRP – Heart Rate Program Setup

NOTE: Perform test wearing Chest Belt.

NOTE: See Page 19 for Target Heart Rate calculation instructions.

1. Stand on the side rails.
2. Press HRP button and the LED will light up.
3. Age will be flashing, adjust Age with the  or  keys at the upper controls.
4. Press ENTER key at the upper controls. Pulse (BPM) will be flashing.
5. Adjust the Pulse (BPM) with the  or  keys at the upper controls.
6. Press ENTER key at the upper controls. Time will be flashing.
7. Adjust the Time with the  or  keys at the upper controls.
8. Press ENTER at the upper controls or QUICKSTART at lower controls at any time to begin.

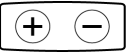
CUSTOM PROGRAMS (4 Custom programs)





1. Stand on the side rails.
2. Press one of the C1 or C2 or C3 or C4 buttons located at the upper left corner of the controls. An LED will light up indicating the program selected.
3. Time will be flashing in the display window.
4. Adjust the Time with the  or  keys on the upper controls.
5. Press ENTER at upper controls. SE01 (Segment #1) will display.
6. Adjust the speed of this segment with the  keys at lower controls or speed number buttons on upper controls.
7. Adjust the incline of this segment with the  keys at lower controls or incline number buttons on upper controls .
8. Press ENTER at upper controls. SE02 (Segment #2) will display.
9. Repeat steps 6 and 7 for up to SE30 (30 segments).
10. Press ENTER at the upper controls or QUICKSTART at lower controls at any time to begin.

NOTE: Custom programs will be stored in the system for easy retrieval unless you reprogram the segments of the custom program.





CONSOLE OPERATION CONTINUED

REMAINING PRESET PROGRAMS

1. Stand on the side rails
2. Press a program button located at the upper left corner of the upper controls. An LED will light up indicating the program selected
3. Resistance level **X.XL-XX** will flash on the display.
4. Adjust resistance level using the  or  keys on the upper controls.
5. Press ENTER. Time will flash on the display.
6. Adjust time using the  or  keys on the upper controls.
7. Press ENTER to begin.

QUICKSTART

1. Stand on the side rails.
2. Press QUICKSTART on lower controls.
3. Adjust Speed with instant speed keys or  on the lower controls.
4. Adjust Incline with instant incline keys or  on the lower controls.



WARRANTY

North American Warranty

Warranties may vary in other countries. See your local BH Fitness Dealer.

WARRANTY SUBMITTAL

Please have the following information available when contacting your dealer or BH for warranty support.

- A copy of the dated purchase receipt or credit card statement.
- An explanation the problem/malfunction, or parts that are missing or damaged.
- Owner's name, address and phone number.
- Model (Treadmill T7) and Serial Number (when available).

Forward your information to BH North America by

FAX: (949) 206-0013

E-mail: fitness@bhnorthamerica.com

Mail to: 20155 Ellipse, Foothill Ranch, California 92610, USA

For troubleshooting assistance or to confirm your claim please phone:

(949) 206-0330

BH FITNESS extends the following exclusive, limited warranty, which shall apply only to the use of the unit in the home, or commercial facilities. Any other use of the unit shall void this warranty.

FRAME – Lifetime – (Home Warranty) / Lifetime – (Institutional Warranty)

BH Fitness warrants the Frame against defects in workmanship and materials for Lifetime from the date of original purchase, so long as it remains in the possession of the original owner for home use.

BH Fitness warrants the Frame against defects in workmanship and materials for Lifetime from the date of original purchase, so long as it remains in the possession of the original owner for Institutional use.

DRIVE MOTOR – Lifetime – (Home Warranty) / 10 Years – (Institutional Warranty)

BH Fitness warrants the Drive Motor against defects in workmanship and materials for Lifetime years from the date of original purchase, so long as the unit remains in the possession of the original owner for home use.

BH Fitness warrants the Drive Motor against defects in workmanship and materials for ten years from the date of original purchase, so long as it remains in the possession of the original owner for Institutional use.

PARTS – 10 Years (Home Warranty) / 5 Years – (Institutional Warranty)

BH Fitness warrants all original parts against defects in workmanship and materials for a period of ten years from the date of original purchase, so long as the unit remains in the possession of the original owner for home use.

BH Fitness warrants all original parts against defects in workmanship and materials for a period of five years from the date of original purchase, so long as the unit remains in the possession of the original owner for Institutional use.



WARRANTY

LABOR – 2 Years – (Home Warranty) / 1 Year – (Institutional Warranty)

BH Fitness shall cover the labor cost for the repair of the unit for a period of two years from the date of original purchase, so long as the unit remains in the possession of the original owner for home use.

Labor warranty does not include the travel time and or expense that may result from the unit being outside of the seller or repair technician's normal service zone.

BH Fitness shall cover the labor cost for the repair of the unit for a period of one year from the date of original purchase, so long as the unit remains in the possession of the original owner for Institutional use. Labor warranty does not include the travel time and or expense that may result from the unit being outside of the seller or repair technician's normal service zone.

EXCLUSIVE REMEDY

The exclusive remedy for any of the above warranties shall be repair or replacement of defective parts, or the supply of labor to cure any defect, provided that labor shall be limited as detailed above. All labor shall be supplied by the local retailer and the product must be located within the retailer's service area. Labor warranty does not include the travel time and or expense that may result from the unit being outside of the seller or repair technician's normal service zone.

EXCLUSIONS AND LIMITATIONS

This warranty applies only to the original owner and is not transferable. This warranty is expressly limited to the repair or replacement of a defective Frame or defective part and is the sole remedy of the warranty. The warranty does not cover normal wear and tear.

BH FITNESS expressly disclaims all other warranties, express or implied, including but not limited to all warranties of fitness for a particular purpose or of merchantability. This warranty gives you specific legal rights and your rights may vary from state to state.

WARRANTY REGISTRATION

Your warranty card must be completed and sent to BH FITNESS before a warranty claim can be processed.