



Treadmill Owner's Manual

BH Fitness T1 Basic



BH FITNESS
20155 Ellipse
Foothill Ranch, CA 92610
Phone: 949-206-8152
Fax: 949-206-0013
Email: fitness@bhnorthamerica.com

Revision Date: 4/25/07



INTRODUCTION:

Congratulations for selecting BH FITNESS as your primary source of fitness. BH FITNESS treadmills offer many exercise programs that benefit users of all levels and ages. Your new treadmill is designed to make your workouts more effective and enjoyable. **Please read this entire manual carefully before using your treadmill.** This will allow you to get a full understanding of all the features your BH FITNESS treadmill provides. If you have any questions or concerns, please contact the BH FITNESS or any authorized BH FITNESS distributors in your area.

BH FITNESS
20155 Ellipse
Foothill Ranch, CA 92610
Phone: 949-206-8152
Fax: 949-206-0013
Email: fitness@bhnorthamerica.com

BEFORE YOU BEGIN

It is very important to become familiar with the frequently used components of your BH Fitness treadmill.

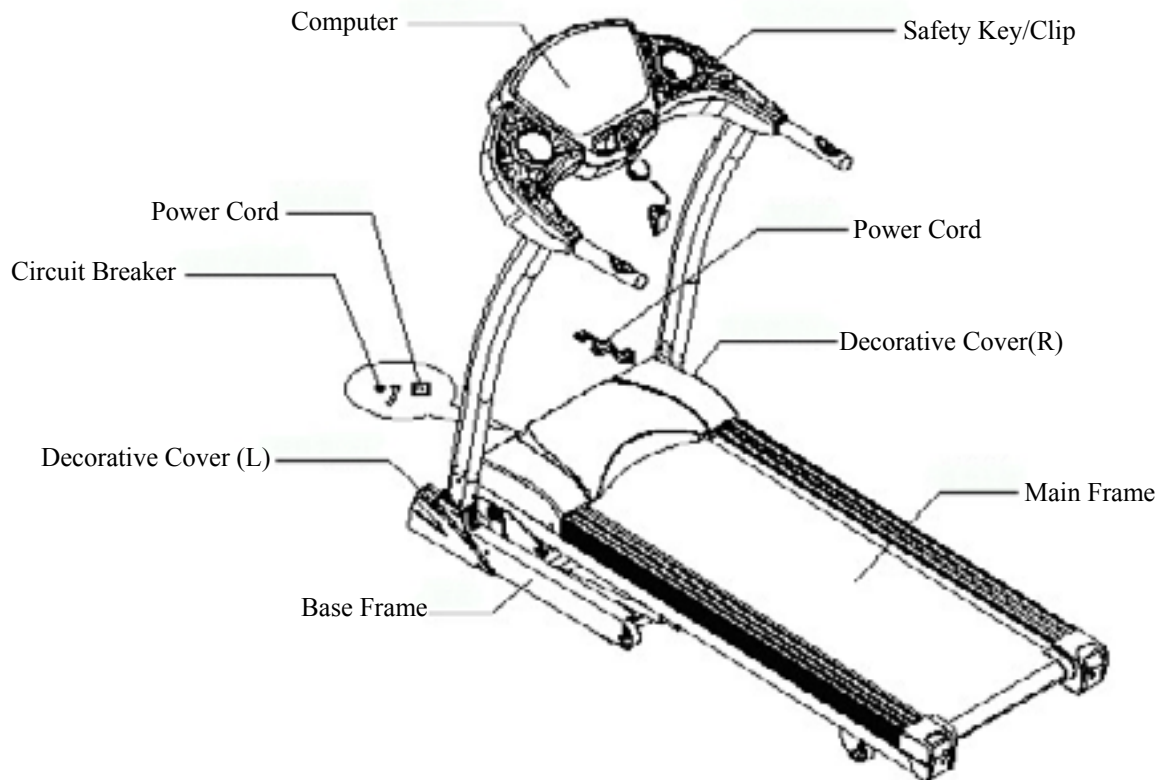



TABLE OF CONTENTS

<u>SECTION</u>	<u>PAGE</u>
1. IMPORTANT SAFETY INSTRUCTIONS.....	3
2. ASSEMBLY INSTRUCTIONS.....	5
3. GETTING STARTED.....	8
4. WORKOUT PROGRAM DETAILS.....	12
5. PREVENTIVE MAINTENANCE.....	19
6. TROUBLESHOOTING.....	20
7. WARRANTY.....	22



SECTION 1

IMPORTANT SAFETY INSTRUCTIONS

Read all instructions before using the treadmill.

Notice: Before using this or any other exercise equipment **consult your family physician or health care professional** to develop a well planned exercise program to fit your health needs. If you encounter any pain or breathing discomfort while working out, **STOP!**, and consult a physician before continuing

WARNING!

1. It is wise to always unplug this appliance from the electrical outlet immediately after use.
2. Keep Children away from machine while in use.
3. Do not wear loose or dangling clothing while using the treadmill
4. Keep a minimum clearance of 18" on each side and 24" at the rear of the treadmill for safety.
5. Maximum user weight for this treadmill is 300 lbs.
6. It is mandatory that you unplug the treadmill prior to cleaning to reduce the risk of electric shock, serious burns, and the risk of injuries.
7. The treadmill should never be left unattended when in operation. Unplug the treadmill from the outlet when not in use or when servicing the treadmill.
8. Close supervision is necessary when this appliance is used by or near children, invalids, disabled persons, or those with diminished capacity.
9. Use this appliance only for its intended use as described in this manual. Do not use any attachment not recommended by the manufacturer.
10. Never operate this appliance if it has a damaged cord or plug, or if it is not working properly. Call your service center for any service concerns before taking your treadmill in for repair.
11. Keep the cord away from heated surfaces.
12. Never drop or insert any object into any opening.
13. Do not use outdoors.
14. Do not operate where aerosol (spray) products are being used or where oxygen is being administered.
15. To disconnect, turn all controls to the off position, then remove plug from outlet.
16. Connect this appliance to a properly grounded outlet only.
17. This appliance is intended for household use only.

SAVE THESE INSTRUCTIONS



IMPORTANT SAFETY INSTRUCTIONS CONTINUED

GROUNDING INSTRUCTIONS

This product must be grounded. If it malfunctions or breaks down, grounding provides a path of least resistance for electric currents, to reduce the risk of electric shock. This product is equipped with a cord which has an equipment-grounding conductor and a grounding plug. The plug must be plugged into an appropriate outlet that is properly installed and grounded in accordance with all local codes and ordinances.

WARNING! – An improper connection of the equipment grounding conductor can result in a risk of an electrical shock. Check with a qualified electrician if you are in doubt as to whether the product is properly grounded. Do not modify the plug provided to you. If it does not fit the outlet, have a proper outlet installed by a qualified electrician.

This product is for use on a nominal 110-120-volt circuit and has a grounding plug that looks like the plug illustrated in the figure. Make sure that the product is connected to an outlet having the same configuration as the plug. No adapter or extension cord should be used with this product.

GROUNDING METHODS

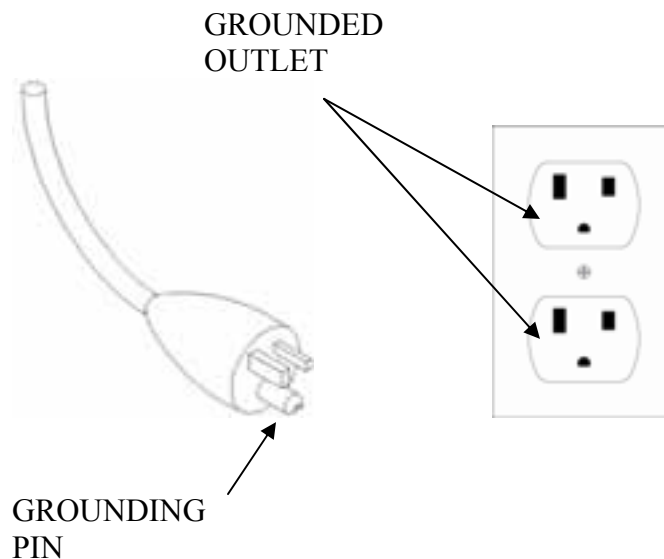



SECTION 2

ASSEMBLY INSTRUCTIONS

ITEM	DESCRIPTION	QTY	ITEM	DESCRIPTION	QTY
A	Computer Console	1	a	Allen Bolt M8xP1.25x15	10
B	Main Frame	1	b	Washer Ø8xØ16x1.5t	10
C	Upright (L)	1	c	Allen Bolt M8xP1.25x60	2
D	Upright (R)	1	d	Screw M5xP0.8x10	4
E	Handrail Protecting Cover	2	e	Allen Key 5mm (70mmx70mm)	1
F	Decorative Cover (L)	1	f	Allen Key 6mm (80mmx80mm)	1
G	Decorative Cover (R)	1	g	Safety Key/Clip	1
H	Bottle	1	h	SILICON	1
			i	Allen Bolt M8xP1.25x50	2

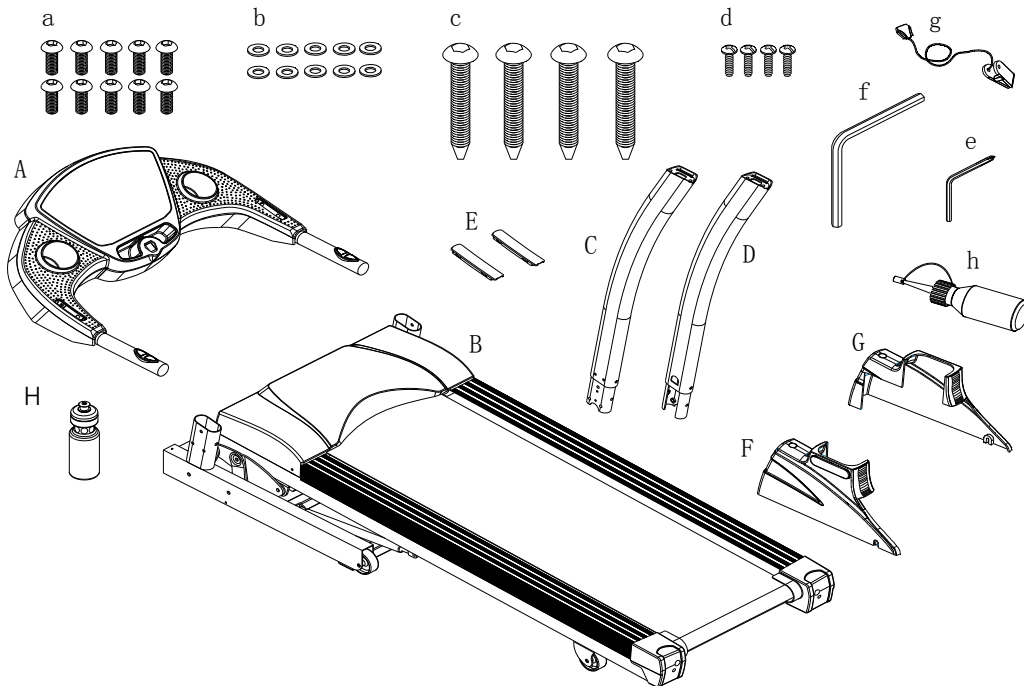



ASSEMBLY INSTRUCTIONS CONTINUED

A minimum of two people are required to assemble this treadmill. Also, READ and understand ALL INSTRUCTIONS thoroughly BEFORE ASSEMBLING the treadmill.

1. Tie the Lower Control Wire of the Main Frame (B) with the Guide Thread of the Right Upright (D), pull the wire into the Upright, and secure with wire clip, then insert into the Upright.
2. Secure the left (C) and right (D) uprights onto the treadmill base with 8 (a) bolts and washers (b).

* Ensure that the wire is not pinched between the upright and the treadmill base when securing the upright



3. After the Uprights are tightened, pull out the Control Wire that has been threaded into the Upright to the position shown in the drawing at the right, then attach the Side Covers (F, G) onto the Frame, and tighten with Screws (d).

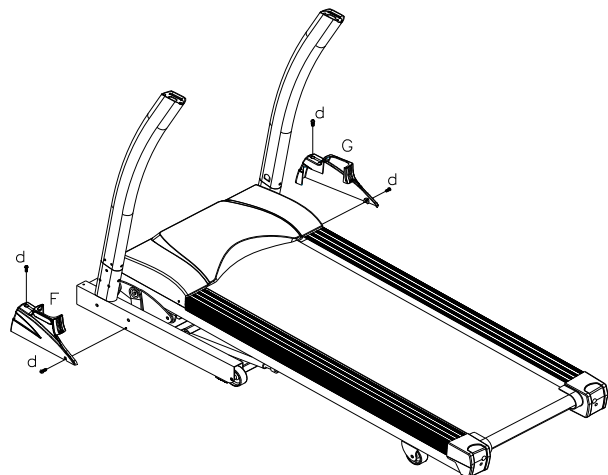



ASSEMBLY INSTRUCTIONS CONTINUED

4. Place the Computer Console (A) on the Upright, then connect the Control Wire of the Main Frame to the Control Wire in the Computer Console (A), then secure with Allen Bolts (c, i).

* When you tighten the bolts, make sure not to damage the control wires in the tube.

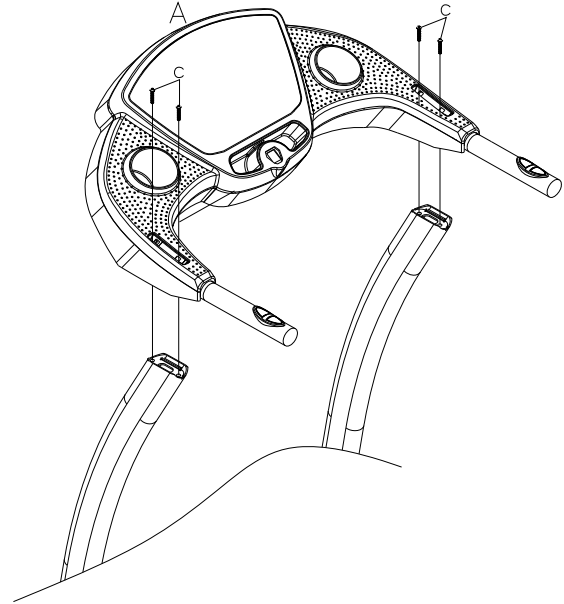

5. After the above step is finished, install the Protecting Covers (E) onto the Handrail bar.

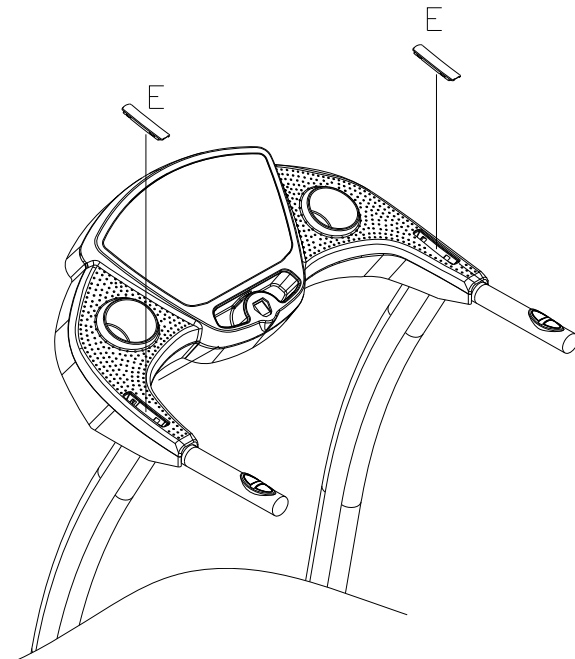



SECTION 3

GETTING STARTED

FOLDING:

To fold your treadmill into the upright position, first be sure to set the elevation to 0% elevation. The treadmill will not lock into the upright position if the treadmill is not at 0 % elevation.

Using both hands, lift the treadmill by the end caps and push it up until the retaining shaft locks the treadmill into place.

UNFOLDING:

To unfold the treadmill from the upright position simply depress the unfolding pedal with your foot and guide the deck down with both hands. The unfolding pedal may be located as shown or near the side. Make sure that you do not let go until the deck is firmly on the floor.

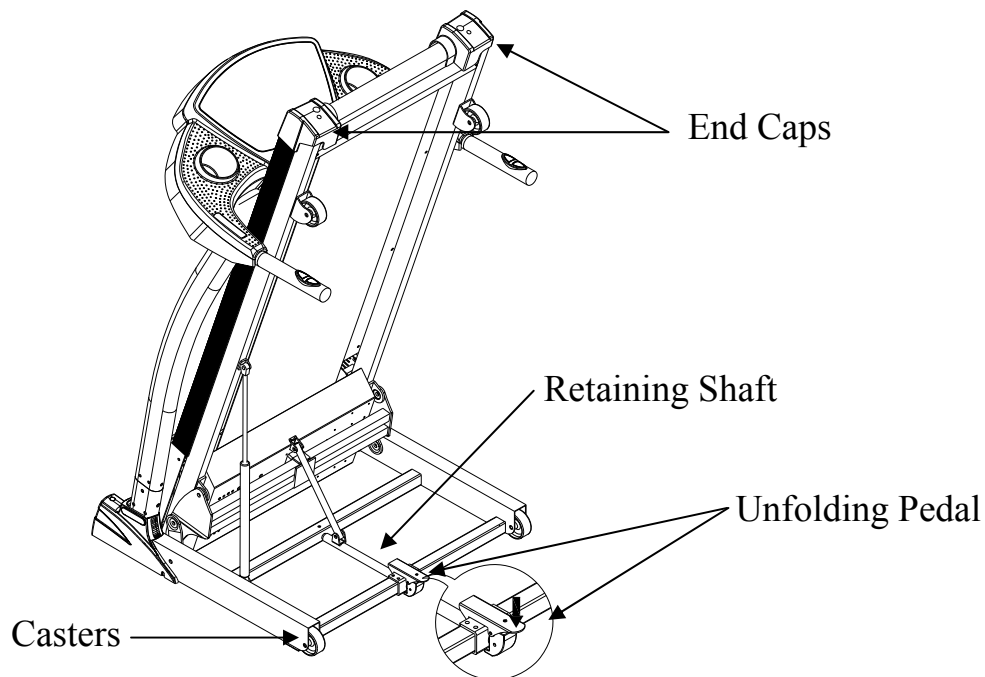

MOVING THE TREADMILL

The treadmill will need to be locked in the upright position as illustrated above. Grab the end caps with both hands and slowly pull the deck down towards your body until the casters are able to roll freely. Keep the treadmill at that angle until you are done with your move. Always be sure to use correct lifting form / technique.



GETTING STARTED CONTINUED

SAFETY KEY & CLIP

Your BH Fitness treadmill is equipped with a safety key that will disable the treadmill if it is not in place. You should attach the clip end to your clothing. The magnet end goes into the recess in the center of the console. If at any time you need to stop the treadmill simply pull the safety key quickly off the console. This will cut all power to the treadmill and it will come to a complete stop. To restart the treadmill, place the safety key back in place. You will then need to program your workout again.

BEFORE STARTING

Straddle the walking belt and stand on the side rails. Insert the safety key and attach the clip to your clothing. Do not stand on the walking belt while starting or stopping the treadmill.

KEY FUNCTIONS

START – This key is used to begin any treadmill program or quick start.

MODE – This key is used to enter into the program mode. It is also used to change the values on the display between incline and pulse.

STOP – This key is used to stop the treadmill at any time. Pressing and holding the STOP button 3 seconds will reset the treadmill.

ENTER – This key is used to confirm your selection.



These keys are used to adjust the speed of the treadmill.



These keys are used to change values during programming. They are also used to adjust the elevation of the treadmill.

INSTANT SPEED KEYS – You can change the speed of the treadmill by pressing one of the Instant Key buttons. The keys represent Miles per Hour (MPH).



GETTING STARTED CONTINUED



CONSOLE FEEDBACK

TIME – This will read the number of minutes left in the program that you have selected. In Quick Start, it will read the number of minutes that you have been exercising.

CALORIES – This reading is the amount of body heat in calories burned during your workout. As with all pieces of exercise equipment, this is an estimated value.

INCLINE – Incline will read as a percent of grade.

PULSE – Pulse will read in beats per minute. (BPM).

SPEED – This is how fast you are moving in terms of miles per hour (MPH).

DISTANCE – Total distance traveled during your workout displayed in miles.

USING HEART RATE

GRIP PULSE – To periodically check your heart rate, grasp the sensors on the handrails. The PULSE LED will flash and after about 9 seconds your pulse will be shown in the pulse window.





GETTING STARTED CONTINUED

QUICK START

1. Turn on POWER.



NOTE: For more accurate calorie count, adjust weight to match your own, otherwise skip to step 4.

2. Weight will be flashing in Distance window. (Default 150 lbs.)
3. Adjust weight with  keys.
4. Press START. The running belt will start to move at 0.5 MPH.
5. Adjust Speed with the  keys or Speed Instant Keys.
6. Adjust Incline with the  keys.

TO STOP

1. Step off running belt onto the side rails.
2. Press STOP. The running belt will stop.

Note: For an immediate stop, pull out the safety key from the safety key recess and the treadmill will stop.



SECTION 4





WORKOUT PROGRAM DETAILS

Your BH FITNESS treadmill will provide both manual controlled and factory installed preset workout programs.





In MANUAL, you control the speed and elevation at your discretion. For QUICK START exercise with Time setting, refer to Manual Program.

In PRESET programs, the speed and/or elevation will change in accordance with the program's profile (as illustrated on the following pages).

MANUAL PROGRAM SETUP

1. Turn on POWER.
2. Weight will be flashing in Distance window. (Default 150 lbs.)
3. Adjust weight with  keys.
4. Press MODE key ~ Manual light will be flashing.
5. Press ENTER ~ Time will be flashing.
6. Adjust time with the  keys.
7. Press START.
8. Adjust Speed with the  keys or Speed Instant Keys.
9. Adjust Incline with the  keys.

PROGRAM SETUP

1. Turn on POWER.
2. Weight will be flashing in Distance window. (Default 150 lbs.)
3. Adjust weight with  keys.
4. Press MODE key ~ Manual light will be flashing.
5. Select the program (P1-P6) with the  keys.
6. Press ENTER ~ Speed will be flashing.
7. Adjust speed if you wish with the  keys.
8. Press ENTER ~ Incline will be flashing.
9. Adjust incline if you wish with the  keys.

Note: Program P1, skip steps 10 & 11.

10. Press ENTER ~ Time will be flashing.
11. Adjust time if you wish with the  keys.
12. Press START.



WORKOUT PROGRAM DETAILS CONTINUED

The BH Fitness T1 Basic has 6 preset programs.

SPEED AND ELEVATION CHANGES

9 HOLE WALK

	1	2	3	4	5	6	7	8	9	10	11	12	13	14	15	16	17	18	19	20	21	22	23	24	25	26	27	28	29	30
Elevation	0.0	1.0	1.0	1.0	1.0	1.0	4.0	1.0	1.0	1.0	1.0	4.0	1.0	1.0	1.0	3.0	4.0	1.0	1.0	1.0	1.0	4.0	1.0	1.0	1.0	1.0	1.0	1.0	1.0	0.0
Speed(MI)	1.0	1.5	2.0	3.0	3.0	3.0	3.0	3.0	3.0	3.0	3.0	3.0	3.0	3.0	3.0	3.0	3.0	3.0	3.0	3.0	3.0	3.0	3.0	3.0	3.0	3.0	2.0	1.5	1.0	
Speed(Km)	1.6	2.4	3.2	4.8	4.8	4.8	4.8	4.8	4.8	4.8	4.8	4.8	4.8	4.8	4.8	4.8	4.8	4.8	4.8	4.8	4.8	4.8	4.8	4.8	4.8	4.8	3.2	2.4	1.6	
Program View																														

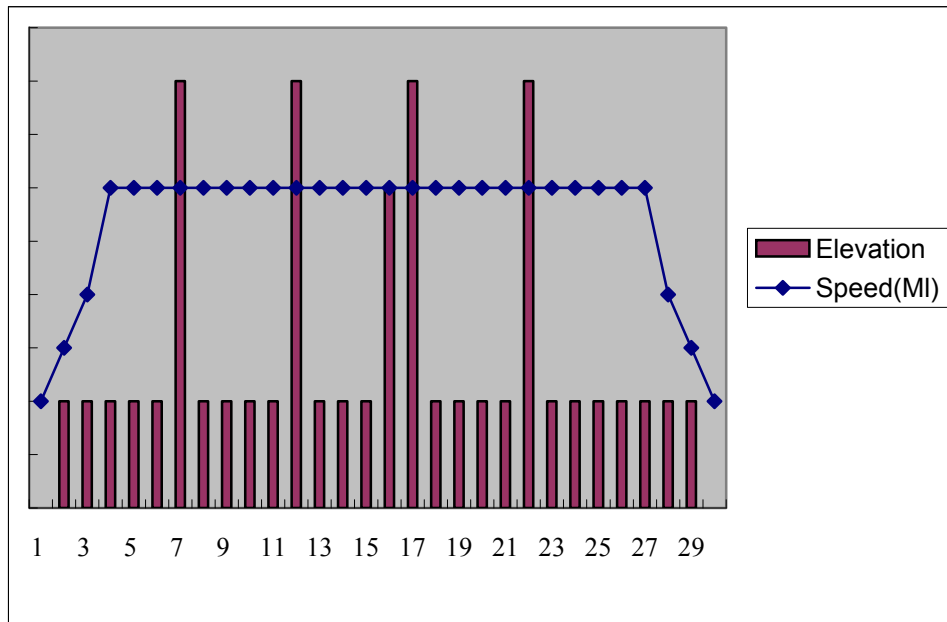

P1 9 HOLE: This program simulates the motion of golfers walking in a golf course and the resistance level is based on uphill and downhill movement. The entire program is approximately 3828 yards or 2.17 miles and will stop automatically once the distance is reached. No time setting is required.



WORKOUT PROGRAM DETAILS CONTINUED

SPEED AND ELEVATION CHANGES

HILL CLIMB

	1	2	3	4	5	6	7	8	9	10	11	12	13	14	15	16	17	18	19	20	21	22	23	24	25	26	27	28	29	30
Elevation	1	2	2	3	3	3	3	4	4	4	4	5	5	5	5	5	5	4	4	4	4	3	3	3	3	2	2	2	1	
Speed(MI)	2.0	2.5	3.0	5.5	3.5	5.5	3.5	6.0	4.0	6.0	4.0	6.0	4.5	6.0	4.5	6.0	4.5	6.0	4.5	6.0	4.0	6.0	4.0	6.0	3.5	5.5	4.5	3.0	2.5	2.0
Speed(Km)	3.2	4	4.8	8.8	5.6	8.8	5.6	9.6	6.4	9.6	6.4	9.6	7.2	9.6	7.2	9.6	7.2	9.6	7.2	9.6	6.4	9.6	6.4	9.6	5.6	8.8	7.2	4.8	4	3.2

Program View

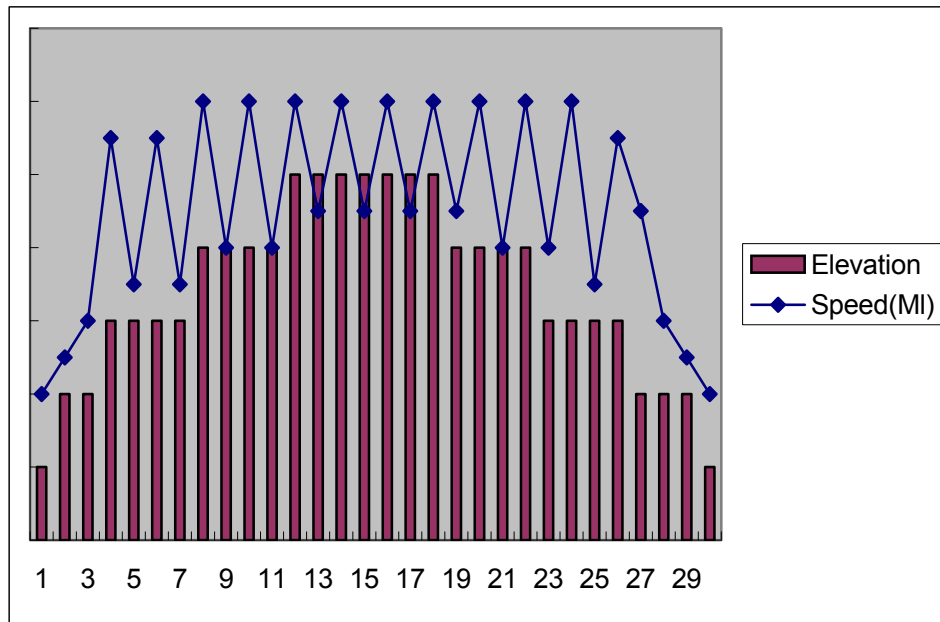



WORKOUT PROGRAM DETAILS CONTINUED

SPEED AND ELEVATION CHANGES

ENDURANCE RUN	1	2	3	4	5	6	7	8	9	10	11	12	13	14	15	16	17	18	19	20	21	22	23	24	25	26	27	28	29	30
Elevation	0	0	0	0	0	1	1	1	1	1	1	1	1	1	1	1	1	1	1	1	1	1	1	1	1	5	4	4	3	2
Speed(MI)	2.0	2.5	3.0	5.0	5.5	6.0	5.5	6.0	5.5	6.0	5.5	6.0	5.5	6.0	5.5	6.0	5.5	6.0	5.5	6.0	5.5	6.0	5.5	6.0	5.5	5.0	4.5	3.0	2.5	2.0
Speed(Km)	3.2	4	4.8	8	8.8	9.6	8.8	9.6	8.8	9.6	8.8	9.6	8.8	9.6	8.8	9.6	8.8	9.6	8.8	9.6	8.8	9.6	8.8	9.6	8.8	8	7.2	4.8	4	3.2

Program View

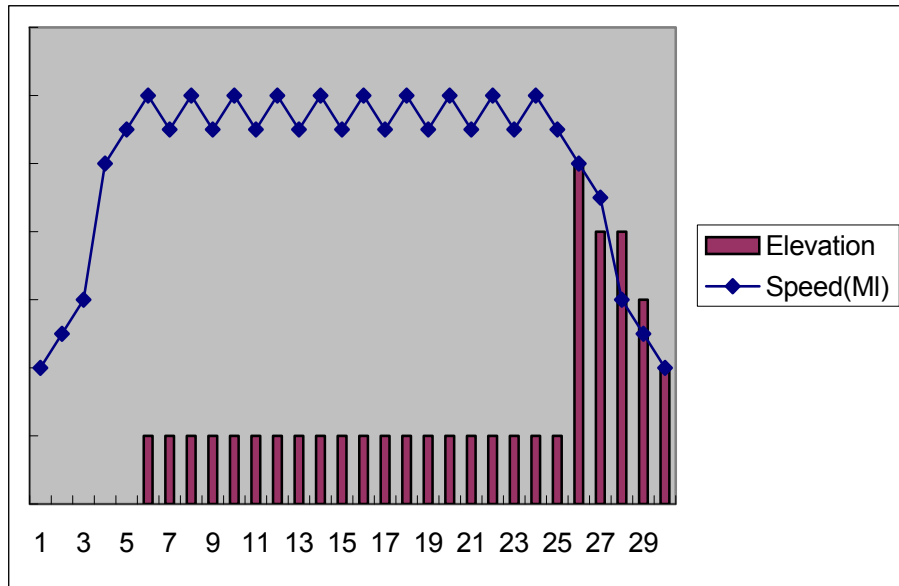



WORKOUT PROGRAM DETAILS CONTINUED

SPEED AND ELEVATION CHANGES

INTERVAL RUN	1	2	3	4	5	6	7	8	9	10	11	12	13	14	15	16	17	18	19	20	21	22	23	24	25	26	27	28	29	30
Elevation	0	0	0	1	1	1	1	1	1	1	1	1	1	1	1	1	1	1	1	1	1	1	1	1	1	1	0	0	0	
Speed(MI)	2.0	2.5	3.0	5.5	4.0	5.5	4.0	5.5	4.0	5.5	4.0	5.5	4.0	5.5	4.0	5.5	4.0	5.5	4.0	5.5	4.0	5.5	4.0	5.5	4.0	5.5	4.5	3.0	2.5	2.0
Speed(Km)	3.2	4	4.8	8.8	6.4	8.8	6.4	8.8	6.4	8.8	6.4	8.8	6.4	8.8	6.4	8.8	6.4	8.8	6.4	8.8	6.4	8.8	6.4	8.8	6.4	8.8	7.2	4.8	4	3.2
Program View																														

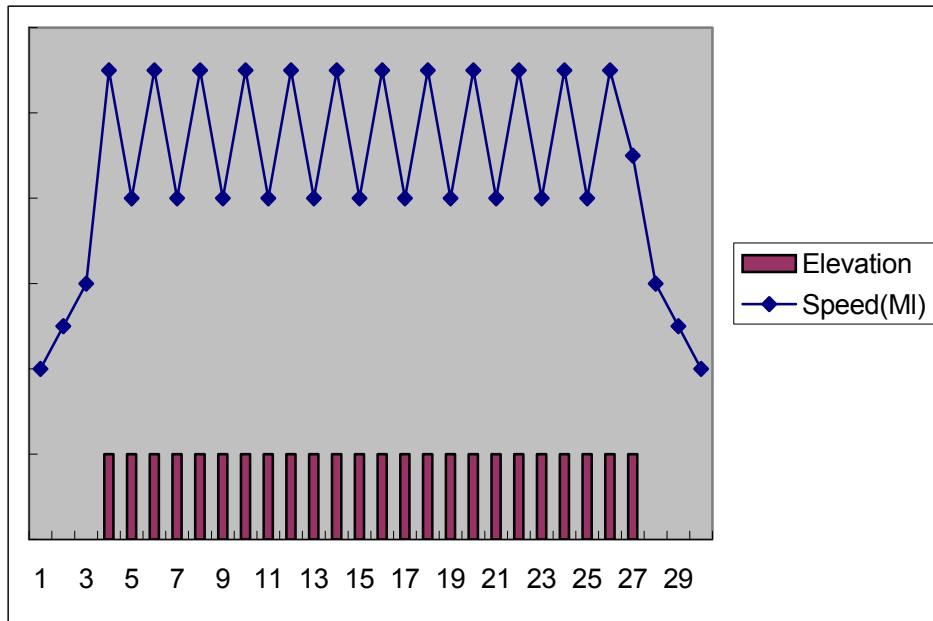



WORKOUT PROGRAM DETAILS CONTINUED

SPEED AND ELEVATION CHANGES

ROLLING RUN

	1	2	3	4	5	6	7	8	9	10	11	12	13	14	15	16	17	18	19	20	21	22	23	24	25	26	27	28	29	30
Elevation	0	0	0	0	0	0	0	0	0	0	0	0	0	0	0	0	0	0	0	0	0	0	0	0	0	0	0	0	0	0
Speed(MI)	2.0	2.5	3.0	4.0	5.0	5.5	5.0	4.5	4.5	5.0	5.5	6.0	5.5	5.0	4.5	4.0	4.5	5.0	5.5	6.0	5.5	5.0	4.5	5.0	5.5	5.0	4.0	3.0	2.5	2.0
Speed(Km)	3.2	4	4.8	6.4	8	8.8	8	7.2	7.2	8	8.8	9.6	8.8	8	7.2	6.4	7.2	8	8.8	9.6	8.8	8	7.2	8	8.8	8	6.4	4.8	4	3.2

Program View

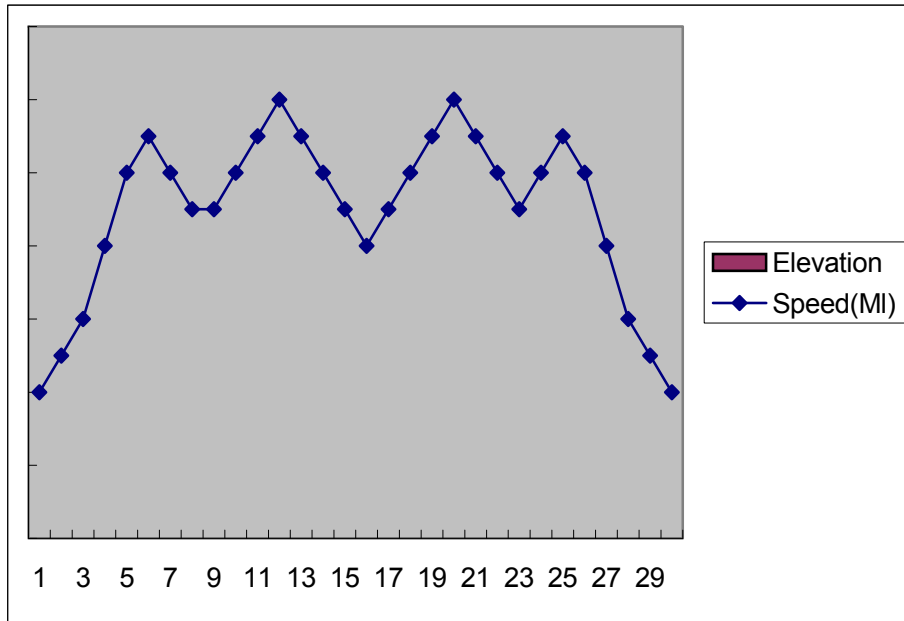



WORKOUT PROGRAM DETAILS CONTINUED

SPEED AND ELEVATION CHANGES

WEIGHT LOSS	1	2	3	4	5	6	7	8	9	10	11	12	13	14	15	16	17	18	19	20	21	22	23	24	25	26	27	28	29	30
Elevation	0	1	1	1	1	1	1	1	1	1	3	3	4	3	1	1	1	2	2	2	1	1	1	1	1	1	0	0	0	
Speed(MI)	2.0	2.5	3.0	3.5	3.5	4.0	4.5	4.5	4.5	4.0	4.0	3.5	3.0	3.5	4.0	4.0	4.0	3.5	3.5	3.5	4.5	4.5	4.5	3.5	3.5	3.5	3.0	2.5	2.0	2.0
Speed(Km)	3.2	4	4.8	5.6	5.6	6.4	7.2	7.2	7.2	6.4	6.4	5.6	4.8	5.6	6.4	6.4	6.4	5.6	5.6	5.6	7.2	7.2	7.2	5.6	5.6	5.6	4.8	4	3.2	3.2

Program View

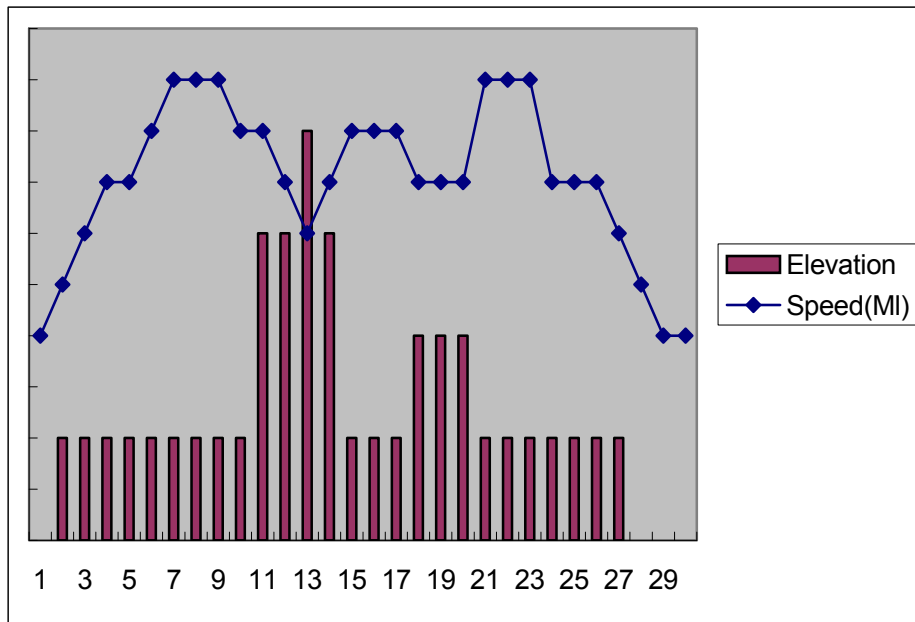

NOTE: The user can manually adjust the speed of any of the preset programs (P1-P6) at any time during the workout by pressing to accelerate or decelerate.

Press to control the elevation. Once the change is made to the program (P1-P6), it will stay at that level until the user makes another change.

There are 30 stages in each PROGRAM. The first 3 stages are WARM UP and the last three stages are COOL DOWN.

The 9 HOLES PROGRAM has no WARM UP and COOL DOWN function. When the distance reaches 2.17 miles, the motor stops, elevation returns to 0 and the program ends.

SECTION 5

PREVENTIVE MAINTENANCE

<p>The running belt can shift to one side or simply ‘skid over’ when running. To center the belt using the 6mm Allen wrench, run the machine at 3mph for a few minutes to determine which side the belt is drifting towards; left or right.</p> <p>If the belt is drifting left</p> <ol style="list-style-type: none"> i) Turn the treadmill off and unplug from the machine ii) Tighten the left bolt a ¼ turn (clockwise) iii) Loosen the right bolt a ¼ turn (counterclockwise) iv) Run the belt at 3 mph again for a few minutes <p style="padding-left: 20px;">If the belt continues to drift to the left, repeat steps</p> <p>If the belt is drifting right</p> <ol style="list-style-type: none"> i) Turn the treadmill off and unplug from the machine ii) Tighten the right bolt a ¼ turn (clockwise) iii) Loosen the left bolt a ¼ turn (counterclockwise) iv) Run the belt at 3 mph again for a few minutes <p style="padding-left: 20px;">If the belt continues to drift to the right, repeat steps</p> <p>Once the running belt has been adjusted closer to the center, the treadmill can be powered on again.</p>	<p style="text-align: center;">Rear Roller Bolt 6 mm wrench</p>
<p>It is recommended that the deck be lubricated every 6~12 months according to the frequency of usage.</p> <p style="text-align: center;">WARNING!</p> <p style="text-align: center;">Do not use cleaner under the running belt.</p> <ol style="list-style-type: none"> i) Use 6mm Allen wrench to loosen the bolts in the end caps. Remove excessive accumulations of dust, dirt, and other substances from running deck. ONLY use a clean soft cloth. ii) Gently pull up the side of the running belt, and dispense a thin layer of the lubricant on deck, and spread evenly. DO NOT over lubricate iii) Center the belt (top of this page), and tighten the end caps. <p>Check belt condition and adjust if necessary referring to the steps above.</p>	<div style="border: 1px solid black; padding: 5px; margin-top: 10px; text-align: center;"> <p>4 Miles or less / hr = lube every 1 year 4~8 Miles / hr = lube every 6 months 8 Miles or more / hr = lube every 3 months</p> </div>



SECTION 6

TROUBLESHOOTING

ERROR MESSAGE	PROBABLE CAUSES	SOLUTION
E1		
- Loss of Feedback	Speed Sensor disconnected	Check Speed Sensor Connection
- Running Deck	Running Deck not lubricated Speed Sensor misaligned	Check R-Deck oil Check Sensor position
	Speed Sensor Faulty	Replace S-Sensor
	Loose Display Cable	Check Display Cable connection
	Faulty MCB (D2 LED on)	Replace MCB
	Drive Motor disconnected	Check D-Motor connection
	Drive Motor Faulty	Replace D-Motor
E6		
- Safety Key Off	Safety Key Faulty	Check Safety Key or Switch
- Elevation Motor	Elevation Motor not moving	Check Elevation Motor connection
- Stalled Elevation	Elevation Motor screw binding	Clean screw and lubricate



TROUBLESHOOTING CONTINUED

ERROR MESSAGE	PROBABLE CAUSES	SOLUTION
	Elevation Motor out of Range	Check Zero Position of E-Motor
	E-Motor Potentiometer	Replace Elevation Motor
E7		
- Elevation Motor	Elevation Motor out of Range	Replace Elevation Motor
- Display Doesn't Light Up	On/Off switch	Check if unit is turned on
	Insufficient Power Source	Plug unit in a dedicated 120V, 20Amp Outlet
	Line Cord Damaged	Replace Line Cord
	Fuse	Check Fuse on MCB



SECTION 7

WARRANTY

USA / CANADA Warranty

Warranties may vary in other countries. See your local BH Fitness Dealer.

BH FITNESS extends the following exclusive, limited warranty, which shall apply only to the use of the device in the home, for residential, non-commercial purposes only. Any other use of the device shall void this warranty.

FRAME – Lifetime

BH Fitness warrants the Frame against defects in workmanship and materials for Lifetime, so long as it remains in the possession of the original owner.

MOTOR – Lifetime

BH Fitness warrants the Motor against defects in workmanship and materials for Lifetime from the date of original purchase, so long as the device remains in the possession of the original owner.

ELECTRONICS & PARTS – 5 Years

BH Fitness warrants the Electronic components and all original parts (other than the Motor) against defects in workmanship and materials for a period of Five years from the date of original purchase, so long as the device remains in the possession of the original owner.

LABOR – 1 Year

BH Fitness shall cover the labor cost for the repair of the device for a period of One year from the date of original purchase, so long as the device remains in the possession of the original owner.

EXCLUSIVE REMEDY

The exclusive remedy for any of the above warranties shall be repair or replacement of defective parts, or the supply of labor to cure any defect, provided that labor shall be limited to one year. All labor shall be supplied by the local retailer and the product must be located within the retailer's service area. Products located outside the retailer's service area will not be covered by the labor warranty.

EXCLUSIONS AND LIMITATIONS

This warranty applies only to the original owner and is not transferable. This warranty is expressly limited to the repair or replacement of a defective Frame, Electronic component, or defective part and is the sole remedy of the warranty. The warranty does not cover normal wear and tear.

BH FITNESS expressly disclaims all other warranties, express or implied, including but not limited to all warranties of fitness for a particular purpose or of merchantability. This warranty gives you specific legal rights and your rights may vary from state to state.

WARRANTY REGISTRATION

Your warranty card must be completed and sent to BH FITNESS before a warranty claim can be processed.